



BROWN & GAMMONS LTD

Tel: 01462 490049 Fax: 01462 491940

www.ukmgparts.com

sales@ukmgparts.com

ACC5292 FRONT PARKING LAMP, WHITE FITTING INSTRUCTIONS MGA 1500 and Early MGA Twin Cam

Components of the Assembly

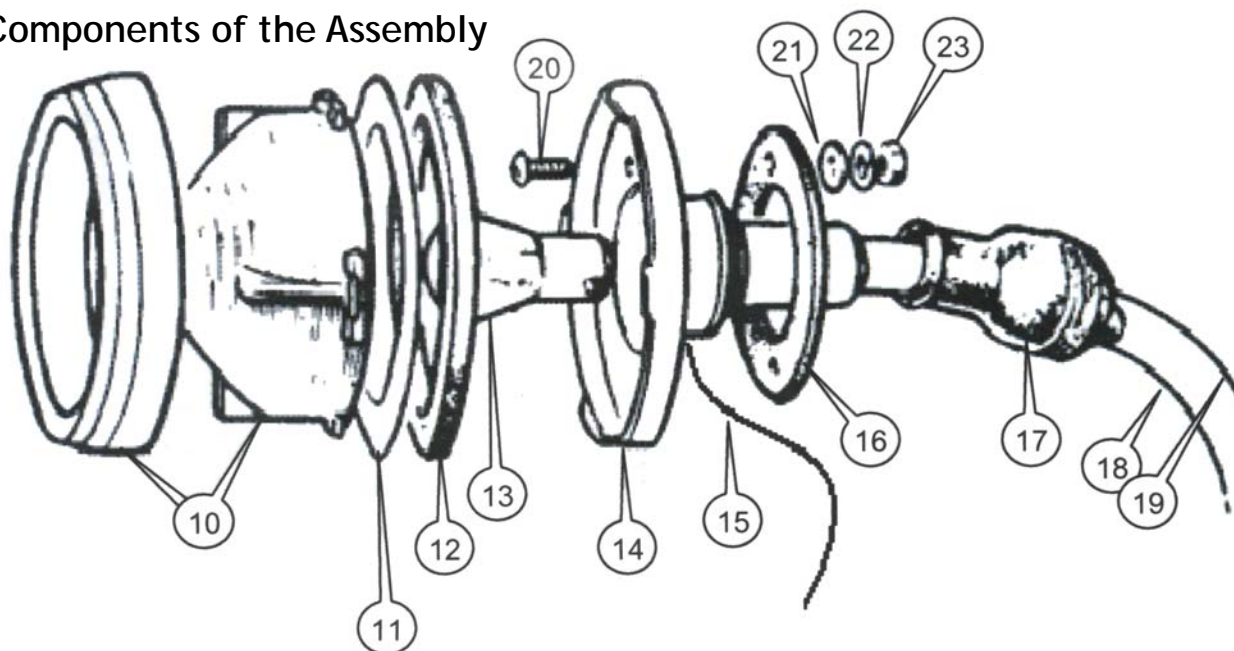

No	Part Number	Description	Qty
10	17H5428	Lens with Rim	1
11	17H5305	Pad, lens (thin, clear plastic)	1
12	17H5308	Pad, lens (thick, foam)	1
13	GLB380	Bulb, 2 filament, 21W/5W	1
14	AJH5151	Lamp base plate with socket	1
15		Black ground wire	1
16	37H5525	Pad, rubber, lamp to fender	1
17	37H5525	Boot, rubber, lamp socket, 2 wire	1
18		Green wire, turn signal (in black plastic sleeve)	1
19		Red wire, parking lamp (in black plastic sleeve)	1
		<i>Not included but useful information</i>	
20	PMZ206	Screw, Phillips 6-32 x 3/8, pan head zinc	2
21		Flat washer, no 6	2
22		Lock washer, no 6	2
23		Nut, 6-32	2



BROWN & GAMMONS LTD

Tel: 01462 490049 Fax: 01462 491940

www.ukmgparts.com

sales@ukmgparts.com

Testing

Fit the bulb into the socket. Note the offset pins (2A, 2B) on the bulb; it can only be fitted one way. Ground the black wire to the negative terminal on a battery. The running lights on both the L/H and R/H side are fed through the RED wire. This wire feeds current to the thin 5 watt filament in the bulb. The turn signals are fed through the GREEN wire. This wire feeds current to the thick 21 watt filament in the bulb. The turn signal will therefore be much brighter than the parking lamp.

If the wires seem to be backwards (GREEN is dim, RED is bright) the white plastic contact plate inside the socket is 180° out and it needs to be rotated. Remove the bulb and look down inside the socket, noting the position of the two locating tabs (2C) and the relative position of the brass contacts (2D). Push on the red and green wires in the sleeve until the white plastic contact plate is free of the socket. Rotate the wires and the sleeve until the contact plate has been rotated 180° and push it back down inside the socket so the tabs on the contact plate are in the grooves. Re-install the bulb and test it again.

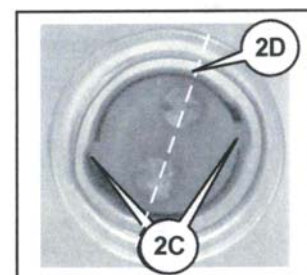
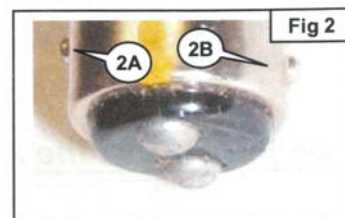

Fitting the Rubber Boot

We supply a non-original boot to protect the socket from mud and moisture in the inner wing well. If we can come up with a more original boot, we will stop supplying this one. In the meantime, we feel the protection is so important that a non-original part is preferable to none at all. This boot is a reproduction of a later Lucas part and will require modification to work in this application. The boot has two sleeves (3A) sized for individual wires. Cut the two projecting sleeves off with a single edged razor blade or Exacto knife. Slice the boot (4A) connecting the two holes. By squeezing the boot (Fig 5) the slit will open and you can slide the boot over the black plastic sleeve and finally, push the boot over the socket. If you want, you can put a dab of silicon RTV on the boot to help seal the hole where the sleeve comes out.

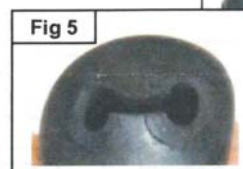
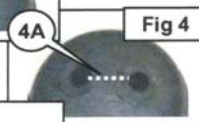
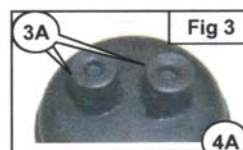

Mounting The Lamp Base

The factory parts book for the MGA1500 only lists the PMZ206 screw, the washers and nut are illustrated but not listed by part number. Although PMZ206 was originally a zinc plated Phillips head screw (5A), you may find screws with Pozi-Drive heads because the Phillips head was dropped in favour of the Pozi-Drive head mid-way through MGA production in the sixties. Although the factory book says two screws are used per lamp (5A), many MGAs use 3 screws per lamp (6A, 6B). The black rubber gasket (Fig 1, no16) goes between the body and the back of the lamp base. The screws that held the lamp to the wing are probably either rusted, or they may have been replaced. If the hardware must be replaced we suggest using stainless steel 6-32 screws, no6 flat washer and Nyloc nuts. The stainless steel will not rust and Nyloc nut will not vibrate loose. The no6 screws are undersized for the holes and that allows a little adjustment in the position of the lamp base.

Note that the top tab (3D) may not be at 12 o'clock. It may be, as in this case, be offset slightly clockwise. This is normal and correct and it makes it easier to get the fin on the lamp lined up with the seam in the wing.

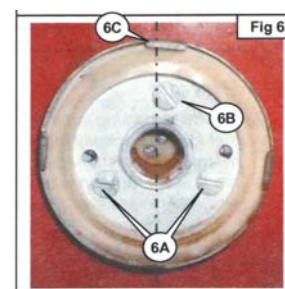
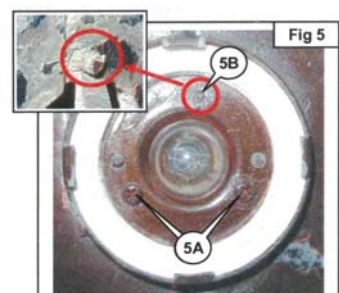



BROWN & GAMMONS LTD

Tel: 01462 490049 Fax: 01462 491940

www.ukmgparts.com

sales@ukmgparts.com

Hooking up the Wires

Both sides: connect the black wire from the lamp to black wire in the harness.

Both sides: connect the red wire from the lamp to the red wire in the harness.

On the L/H side hook the green wire from the lamp to the green wire/red tracer.

On the R/H Side hook the green wire from the lamp to the green wire/white tracer.

Before you fit the lens, check the operation of the parking lamps and turn signals. If the lamps don't work, check your ground leads first.

Fitting the Lens

Place the foam gasket (Fig 1, no12) inside the lamp base. Place the thin clear plastic gasket (Fig 1, no11) on top of the foam gasket. The thin plastic gasket protects the foam gasket as you rotate the lens to lock it in place. Look at the backside of the lens and rim assembly and locate the four locking flanges (fig 4). Hold the lens against the lamp base and press in (to compress the gasket) and rotate the lens assembly clockwise until the lens is locked in place. The flanges on the lens (Fig 4) will engage the four tabs (3D) on the rim of the lamp base. One "fin" on the lens should line up with the wing seam (5A).

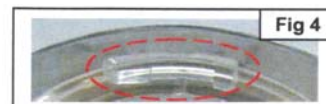

Brake Light & Indicators, MGA 1500

This 1500 uses just one filament in the rear lamps for both brake light and turn signal, so it incorporates a relay box to switch the bulb out of the brake light circuit and into the turn signal circuit when you operate the switch on the dash. Snap connectors labelled EC are in the engine compartment near the starter switch.

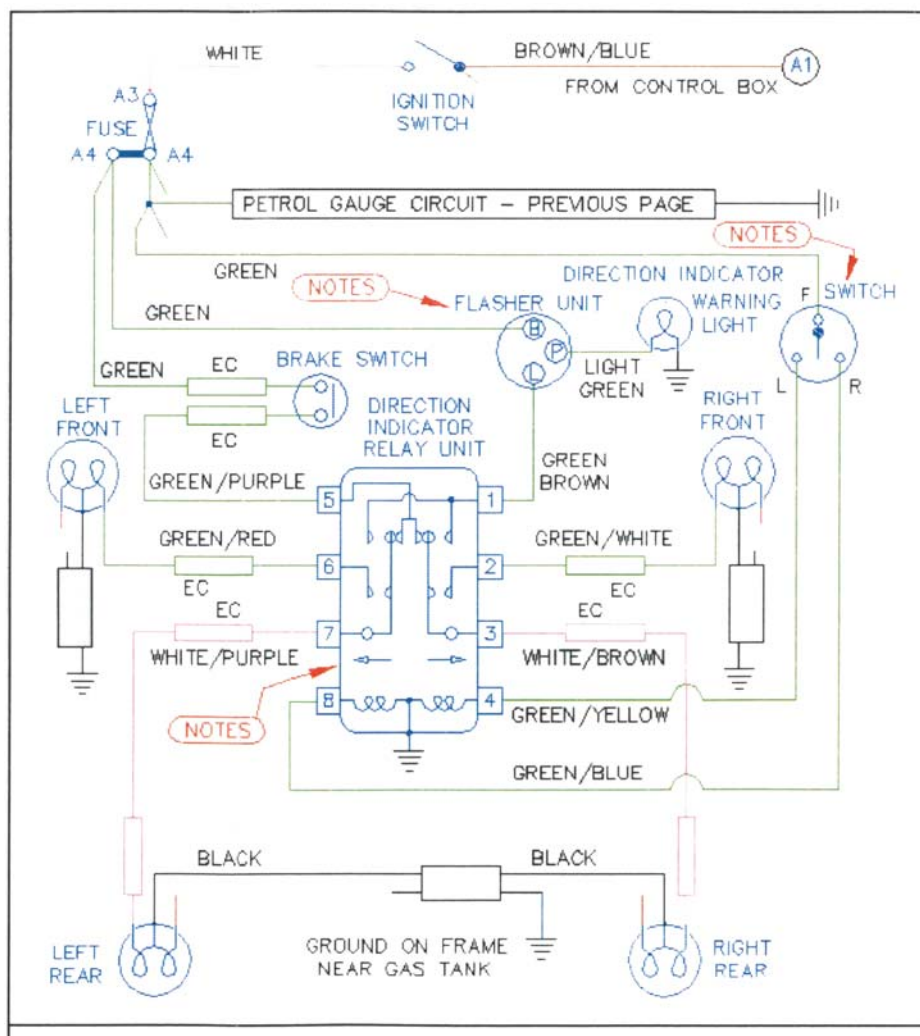



BROWN & GAMMONS LTD

Tel: 01462 490049 Fax: 01462 491940

www.ukmgparts.com

sales@ukmgparts.com

Brake Light & Indicators, MGA 1500

Shown below is the MGA direct circuitry. These circuits are not fused, presumably because a burned fuse would cause all of the lights to go out. The snap connectors are labelled EC are located in the right rear corner of the engine bay.

